



ATLASTIC® 40 MEMBRANE

DESCRIPTION

ATLASTIC 40 MEMBRANE is a hot applied, textile reinforced membrane consisting of ATLASTIC 31, a hot melt asphaltic compound, and ATLASTIC 40 TEXTILE, an asphaltic coated glass fabric. It is used to form an impervious, chemical resistant membrane between a substrate and chemical resistant brick sheathing.

TYPICAL USES

ATLASTIC 40 MEMBRANE is recommended for horizontal and vertical, concrete and steel surfaces. It is used in industrial floor systems, pits, tanks, sumps and trenches. ATLASTIC 40 MEMBRANE is applied in a minimum 1/4" (6.4 mm.) thickness. Brick sheathing is required over ATLASTIC 40 MEMBRANE to provide physical and thermal protection for the membrane.

CHEMICAL RESISTANCE

ATLASTIC 40 MEMBRANE is resistant to many acids, alkalis and salts at ambient temperatures. Refer to the chemical resistance chart for specific information.

PACKAGING AND COVERAGE

ATLASTIC 31 PRIMER

5-gallon pail (35 lb. [15.9 kg.])
Coverage: Approx. 500 sq. ft. (46.5 m²)
Coverage as a Conductive Primer: Approx. 300 sq. ft. (27.9 m²)

ATLAS® CARBON POWDER

5-gallon pail (38 lb. [17.2 kg.])
When conductive primer is required, add 1.5 lb. (680 g.) per 1-gallon of ATLASTIC 31 PRIMER

ATLASTIC 31

13-3/4-gallon fiber drum
Coverage: Approx. 67 sq. ft. (6.2 m²) @ 1/4" (6.4 mm.) thickness

ATLASTIC 40 TEXTILE

450 sq. ft. (41.8 m²) roll
Coverage: Approx. 410 sq. ft. (38.6 m²) per roll

SURFACE PREPARATION

ATLASTIC 40 MEMBRANE can be applied to concrete and steel surfaces. The substrate must be structurally sound, clean, dry and free of all

PHYSICAL PROPERTIES (unreinforced asphalt)

PROPERTY	TEST METHOD	TYPICAL VALUE
Softening Point	ASTM D36	212°F (100°C)
Flash Point	ASTM D92	550°F (288°C)
Fire Point	ASTM D92	600°F (316°C)
Ash	ATM No. 18	< 0.5%
Penetration @ 32°F (0°C), 200 g. - 60 seconds	ASTM D5	20
Penetration @ 77°F (25°C), 100 g. - 5 seconds	ASTM D5	40
Penetration @ 115°F (46°C), 50 g. - 5 seconds	ASTM D5	75
Ductility @ 75°F (24°C)	ASTM D113	2.5 cm.
Specific Gravity @ 75°F (24°C)	ASTM D71	0.95 to 1.1
Maximum Temperature @ Face of Membrane		150°F (66°C)

contaminants such as sealers, curing compounds, coatings, oil, dirt, dust and water. Previously applied coatings or paint must be removed.

Concrete: Finished concrete must be free of ridges, protrusions, fins, mortar splatter and have a tight laitance-free steel trowel finish. Abrasive grit blasting or acid washing are recommended surface preparation methods. A finish similar to the profile of 100 to 120 grit sandpaper is suggested.

Steel: Surfaces must be free of grease, oil or other contaminants. To remove grease or oil, clean surface with solvent. Final wiping should be done with clean solvent and clean rags. Grit blast to a three to four mil profile. A NACE #1 white metal finish is recommended. After grit blasting, remove all residue with a commercial type vacuum. Finished surface should be free of rust, mill scale, paint and any other contaminants.

For additional information, refer to Surface Preparation, Data Sheet PS-30 and Specification for Concrete Floor Slabs, Data Sheet 3-12DN.

MIXING AND APPLICATION OF THE ATLASTIC 31 PRIMER

ATLASTIC 31 PRIMER is a one component product. Stir the ATLASTIC 31 PRIMER prior to application by brush or roller.

Concrete: Apply a uniform, continuous coat of ATLASTIC 31 PRIMER. Thoroughly work it into the pores of the concrete. Do not allow puddling. Allow to dry until tack-free. Refer to the "Typical Drying Times" chart.

TYPICAL DRYING TIMES OF THE ATLASTIC 31 PRIMER

Temperature	Drying Time
60°F (16°C)	5 hours
70°F (21°C)	4 hours
80°F (27°C)	3 hours

Conductive Primer: When a conductive primer is required, apply a uniform, continuous coat of ATLASTIC 31 PRIMER with ATLAS CARBON POWDER. Add 1.5 lb. (680 g.) of ATLAS CARBON POWDER to 1-gallon of ATLASTIC 31 PRIMER. Mix using a hand drill equipped with a "Jiffy" type mixer at a mixing speed between 300 and 500 RPM to thoroughly disperse. If the material is not used immediately, **stir again before using**. Apply the conductive primer by brush. Allow to dry until tack-free.

Steel: Apply a uniform, continuous coat of ATLASTIC 31 PRIMER. Allow to dry until tack-free.

APPLICATION OF THE ATLASTIC 31 AND ATLASTIC 40 TEXTILE

Material estimating quantities may vary depending on project conditions and application techniques. Material quantities are theoretical and do not include a safety factor.

- Break up ATLASTIC 31 and melt in a roofer's pot or a 5-gallon electric bucket heater until hot enough to flow, approximately 400°F (204°C) to 450°F (232°C).
- For vertical surfaces, apply melted ATLASTIC 31 with a tempered masonite squeegee (see diagram). Pour the molten material on the squeegee while holding the squeegee against the wall to form a container. Starting at the lowest point, raise the squeegee and pour to form a coating on the walls as the ATLASTIC 31 cools. Continue pouring, overlapping slightly each time, until a uniform thickness results. The ATLASTIC 31 can be smoothed slightly with the squeegee between pours.
- Pour three to four gallons of melted ATLASTIC 31 at a time onto horizontal surfaces and spread to uniform thickness using a tempered masonite squeegee or a similar material able to be manipulated with one hand. Inspect surfaces for pinholes and mark defects with chalk. Ensure pinholes are covered properly in subsequent applications.
- Apply sufficient coats to form a 1/8" (3.2 mm.) layer. Multiple layers ensure a pinhole free membrane.
- Place ATLASTIC 40 TEXTILE onto the surface and smooth as much as possible. All edges must overlap at least 2" (5.1 cm.). A masonite squeegee can be used as a straight edge to smooth and embed the ATLASTIC 40 TEXTILE into the ATLASTIC 31.
- After the ATLASTIC 40 TEXTILE is placed, apply ATLASTIC 31 to obtain a final thickness of 1/4" (6.4 mm.). Work out all bubbles as the application proceeds. The finish coat must be free of all bubbles and carefully smoothed to provide a uniform finish.

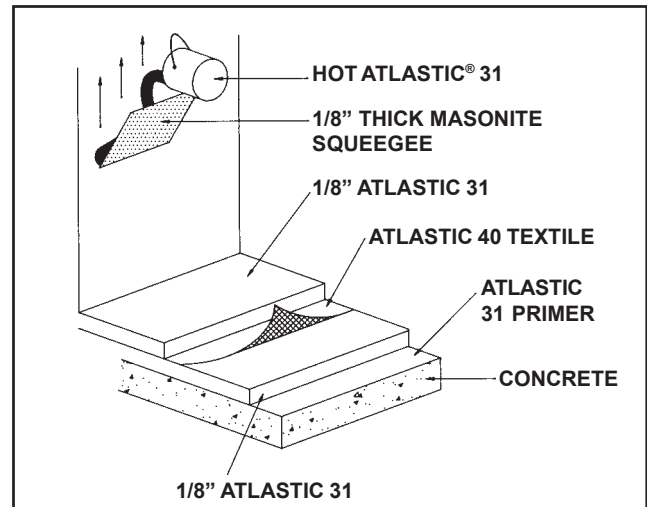
APPLICATION ON VERTICAL SURFACES

Note: Any Atlas Mortar Powder can be sprinkled over the finished surface to prevent sticking to workmen's shoes or boards which have been laid down as walkways. If powder is used between layers, sweep it up before applying the next layer or the layers will not adhere to each other. **NO TRAFFIC OR EQUIPMENT SHOULD BE ALLOWED ON THE MEMBRANE UNTIL THE BRICK SHEATHING, WHICH IS ALWAYS REQUIRED, IS INSTALLED.**

CLEANING OF TOOLS AND EQUIPMENT

Kerosene, odorless mineral spirits or hi-flash naphtha may be used for cleaning of tools and equipment. **UNDER NO CIRCUMSTANCES SHOULD KEROSENE BE ADDED TO THE ATLASTIC 31 PRIMER.**

Dispose of residues and wastes in accordance with the directions in the Material Safety Data Sheets and government regulations.

STORAGE AND SHELF LIFE

Store all materials in a cool, dry environment. Keep all materials out of direct sunlight. Ideal storage temperature is 75°F (24°C). In unopened original containers, the materials referred to in this Data Sheet have a shelf life of approximately one year.

PRODUCT SPECIFICATION

The membrane shall be ATLASTIC 40 MEMBRANE as manufactured by Atlas Minerals & Chemicals, Inc.

PRECAUTIONS

The materials referred to in this Data Sheet are for Industrial Use Only. They contain materials that present handling and potential health hazards. Consult Material Safety Data Sheets and the container labels for complete precautionary information.

TECHNICAL SERVICES

ATLAS maintains a staff of Technical Service Representatives who are available to assist you with the use of ATLAS products. In the event of difficulties with the application of ATLAS materials, the installation should be stopped immediately and ATLAS' Technical Service Department consulted for assistance.

WARRANTY

ATLAS warrants that its products will be free from defects in workmanship and materials under normal use for a period of one (1) year from the date of shipment by ATLAS (provided the products are installed before the expiration of the shelf life). THERE ARE NO EXPRESS OR IMPLIED WARRANTIES OF MERCHANTABILITY OR FITNESS FOR THE PURPOSE FOR THIS PRODUCT WHICH EXTEND BEYOND THE DESCRIPTION ON THE FACE HEREOF. ATLAS' LIABILITY FOR ALLEGED BREACH OF THIS WARRANTY SHALL BE LIMITED TO REPAIR OR REPLACEMENT OF THE DEFECTIVE PRODUCT (BUT NOT INCLUDING REMOVAL OF THE DEFECTIVE PRODUCT OR INSTALLATION OF REPLACEMENT PRODUCTS). ATLAS SHALL NOT BE LIABLE FOR ANY INCIDENTAL OR CONSEQUENTIAL DAMAGES DURING THE WARRANTY PERIOD OR THEREAFTER. **ATLAS' WARRANTY IS VOIDED IF PAYMENT FOR PRODUCT IS NOT RECEIVED IN FULL.**

CHEMICAL RESISTANCE OF ATLASTIC® 40 MEMBRANE (4-40PI)

	80°F	150°F
Acetaldehyde	C	C
Acetic Acid, to 10%	C	N
Acetic Acid, Glacial	N	N
Alum or Aluminum Sulfate	R	R
Aluminum Chloride, Nitrate, Sulfate	R	R
Ammonium Chloride, Nitrate, Sulfate	R	R
Ammonium Hydroxide	R	C
Amyl Acetate	N	N
Amyl Alcohol	R	R
Aniline	N	N
Aqua Regia	N	N
Barium Chloride, Nitrate, Sulfate	R	R
Barium Hydroxide	R	R
Barium Sulfide	C	N
Benzene	N	N
Benzene Sulfonic Acid, 10%	R	R
Benzoic Acid	R	R
Boric Acid	R	R
Bromine Water	N	N
Butyl Acetate	N	N
Butyl Alcohol	R	R
Butyric Acid	N	N
Cadmium Chloride, Nitrate, Sulfate	R	R
Calcium Bisulfite, Chloride, Nitrate	R	R
Calcium Hydroxide	R	C
Carbon Disulfide	N	N
Carbon Tetrachloride	N	N
Chlorine Dioxide, Water Solution	N	N
Chlorine, Dry	R	R
Chlorine, Wet	R	C
Chlorine Water	C	-
Chloroacetic Acid, to 10%	N	N
Chlorobenzene	N	N
Chloroform	N	N
Chromic Acid, to 10%	R	C
Chromic Acid, 10% to 50%	C	C
Chromic Acid, above 50%	N	N
Citric Acid, to 10%	R	R
Copper Chloride, Nitrate, Sulfate	R	R
Dichloroacetic Acid, 10%	N	N
Dichlorobenzene	N	N
Diethyl Ether	N	N
Ethyl Acetate	N	N
Ethyl Alcohol	R	R
Ethyl Sulfate	N	N
Ethylene Dichloride	N	N
Ethylene Glycol	R	R
Fluosilicic Acid	C	C

	80°F	150°F
Formaldehyde	C	C
Formic Acid	C	N
Gasoline	N	N
Glycerine	R	R
Gold Cyanide	R	R
Hexane	N	N
Hydrobromic Acid	R	R
Hydrochloric Acid	R	R
Hydrocyanic Acid	R	R
Hydrofluoric Acid	C	C
Hydrofluosilicic Acid	C	C
Hydrogen Peroxide	C	C
Hydrogen Sulfide Gas, Dry or Wet	R	R
Iron Chloride, Nitrate, Sulfate	R	R
Isopropyl Ether	N	N
Kerosene	N	-
Lactic Acid	R	R
Lead Acetate, Nitrate	R	R
Linseed Oil	N	N
Magnesium Chloride, Nitrate, Sulfate	R	R
Magnesium Hydroxide	R	R
Maleic Acid	R	C
Mercuric Acetate	R	R
Methyl Acetate	N	N
Methyl Alcohol	R	R
Methyl Ethyl Ketone	N	N
Methyl Sulfate	N	N
Mineral Oil	N	N
Mineral Spirits	N	N
Muriatic Acid	R	R
Nickel Chloride, Nitrate, Sulfate	R	R
Nitric Acid, to 5%	R	R
Nitric Acid, 5% to 20%	R	C
Nitric Acid, above 20%	N	N
Nitrobenzene	N	N
Oleic Acid	C	N
Oxalic Acid	R	R
Perchloric Acid	N	N
Phenol, to 5%	N	N
Phosphoric Acid	R	R
Phosphorous Acid	R	R
Phosphorous Trichloride	R	R
Phthalic Acid	R	R
Picric Acid	N	N
Potassium Bicarbonate, Carbonate	R	R
Potassium Chloride, Nitrate, Sulfate	R	R
Potassium Cyanide	R	R
Potassium Ferricyanide, Ferrocyanide	R	R

	80°F	150°F
Potassium Hydroxide, to 30%	R	C
Potassium Hydroxide, above 30%	C	N
Pyridine	N	N
Rochelle Salt	R	R
Salicylic Acid	R	R
Silver Nitrate	R	R
Sodium Acetate	R	R
Sodium Bicarbonate, Carbonate	R	R
Sodium Chloride, Nitrate, Sulfate	R	R
Sodium Cyanide	R	R
Sodium Hydroxide, to 30%	R	C
Sodium Hydroxide, above 30%	C	N
Sodium Hypochlorite, to 3%	C	C
Sodium Hypochlorite, above 15%	N	N
Sodium Sulfide	C	C
Sodium Sulfite, Thiosulfate	R	R
Soya Oil	N	N
Stearic Acid	C	N
Sulfur Dioxide Gas, Dry or Wet	R	R
Sulfur Trioxide Gas, Dry or Wet	R	R
Sulfuric Acid, to 50%	R	R
Sulfuric Acid, 50% to 80%	C	N
Sulfuric Acid, above 80%	N	N
Sulfurous Acid	R	R
Tannic Acid	R	R
Tartaric Acid	R	R
Tin Chloride, Sulfate	R	R
Toluene	N	N
Trichloroethylene	N	N
Trisodium Phosphate	R*	R*
Tung Oil	N	N
Urea	R	R
Xylene	N	N
Zinc Chloride, Nitrate, Sulfate	R	R

KEY

- R - Recommended
- N - Not Recommended
- C - Conditional; May be serviceable if the contaminant is immediately removed or washed off the surface.
- * - For flooring application only.

Note - The information presented in the chemical resistance tables is based on judgments derived from laboratory testing and field service performance. The tables have been prepared as a guide to performance. No guarantee of results is made or implied and no liability in connection with this information is assumed. The information presented herein should be supplemented by in-service testing. The data furnished in the tables may be revised on the basis of further testing.

(2-02)