



Atlas Minerals & Chemicals, Inc.



DATA SHEET

4-50PI (2-02)
Supersedes 4-50PI (12-00)

ATLASTIC 50 MEMBRANE

DESCRIPTION

ATLASTIC 50 MEMBRANE is a corrosion resistant multi-ply reinforced membrane.

TYPICAL USES

ATLASTIC 50 MEMBRANE is used to construct brick lined vessels, manholes, trenches and sumps. Brick sheathings are required to provide physical and thermal protection for the ATLASTIC 50 MEMBRANE, however, the thickness of the sheathing is reduced due to the high softening point of the base asphalt. The phosphate fertilizer, general chemical, steel and metal working industries use this high temperature resistant membrane.

CHEMICAL RESISTANCE

ATLASTIC 50 MEMBRANE is resistant to solutions of alkalis, salts and non-oxidizing acids. It is flexible and stable over a broad temperature range. Refer to the chemical resistance chart for specific information.

PACKAGING AND COVERAGE

ATLASTIC 50 PRIMER

5-gallon pail (35 lb. [15.9 kg.])

Coverage: Approx. 500 sq. ft. (46.5 m²)

Coverage as a Conductive Primer: Approx. 300 sq. ft. (27.9 m²)

ATLAS CARBON POWDER

5-gallon pail (38 lb. [17.2 kg.])

When conductive primer is required, add 1.5 lb. (680 g.) per 1-gallon of ATLASTIC 50 PRIMER

ATLASTIC 50

13-3/4-gallon fiber drum

Coverage: Approx. 67 sq. ft. (6.2 m²) @ 1/4" (6.4 mm.) thickness

ATLASTIC 40 TEXTILE

450 sq. ft. (41.8 m²) roll

Coverage: Approx. 410 sq. ft. (38.1 m²) per roll

SURFACE PREPARATION

ATLASTIC 50 MEMBRANE can be applied to concrete and steel surfaces. The substrate must be structurally sound, clean, dry and free of all contaminants such as sealers, curing compounds, coatings, oil, dirt, dust and water. Previously applied coatings or paint must be removed.

PHYSICAL PROPERTIES (unreinforced asphalt)

PROPERTY	TEST METHOD	TYPICAL VALUE
Softening Point	ASTM D36	275°F (135°C)
Flash Point	ASTM D92	560°F (293°C)
Fire Point	ASTM D92	610°F (321°C)
Ash	ATM No. 18	< 0.5%
Penetration @ 32°F (0°C), 200 g. - 60 seconds	ASTM D5	12
Penetration @ 77°F (25°C), 100 g. - 5 seconds	ASTM D5	18
Penetration @ 115°F (46°C), 50 g. - 5 seconds	ASTM D5	27
Ductility @ 75°F (24°C)	ASTM D113	1.5 cm.
Specific Gravity @ 75°F (24°C)	ASTM D71	0.95 to 1.1
Maximum Temperature @ Face of Membrane		190°F (88°C)

Concrete: Finished concrete must be free of ridges, protrusions, fins, mortar splatter and have a tight laitance-free steel trowel finish. Abrasive grit blasting or acid washing are recommended surface preparation methods. A finish similar to the profile of 100 to 120 grit sandpaper is suggested.

Steel: Surfaces must be free of grease, oil or other contaminants. To remove grease or oil, clean surface with solvent. Final wiping should be done with clean solvent and clean rags. Grit blast to a three to four mil profile. A NACE #1 white metal finish is recommended. After grit blasting, remove all residue with a commercial type vacuum. Finished surface should be free of rust, mill scale, paint and any other contaminants.

For additional information, refer to Surface Preparation, Data Sheet PS-30 and Specification for Concrete Floor Slabs, Data Sheet 3-12DN.

MIXING AND APPLICATION OF THE ATLASTIC 50 PRIMER

ATLASTIC 50 PRIMER is a one component product. Stir the ATLASTIC 50 PRIMER prior to application by brush or roller.

Concrete: Apply a uniform, continuous coat of ATLASTIC 50 PRIMER. Thoroughly work it into the pores of the concrete. Do not allow puddling. Allow to dry until tack-free. Refer to the "Typical Drying Times" chart.

Conductive Primer: When a conductive primer is required, apply a uniform, continuous coat of ATLASTIC 50 PRIMER with ATLAS CARBON POWDER. Add

TYPICAL DRYING TIMES OF THE ATLASTIC 50 PRIMER

Temperature	Drying Time
60°F (16°C)	5 hours
70°F (21°C)	4 hours
80°F (27°C)	3 hours

1.5 lb. (680 g.) of ATLAS CARBON POWDER to 1-gallon of ATLASTIC 50 PRIMER. Mix using a hand drill equipped with a "Jiffy" type mixer at a mixing speed between 300 and 500 RPM to thoroughly disperse. If the material is not used immediately, **stir again before using**. Apply the conductive primer by brush. Allow to dry until tack-free.

Steel: Apply a uniform, continuous coat of ATLASTIC 50 PRIMER. Allow to dry until tack-free.

APPLICATION OF THE ATLASTIC 50 AND ATLASTIC 40 TEXTILE

Material estimating quantities may vary depending on project conditions and application techniques. Material quantities are theoretical and do not include a safety factor.

- Break up ATLASTIC 50 and melt in a roofer's pot or a 5-gallon electric bucket heater until hot enough to flow, approximately 425°F (218°C) to 450°F (232°C).
- For vertical surfaces, apply melted ATLASTIC 50 with a tempered masonite squeegee (see diagram). Pour the molten material on the squeegee while holding the squeegee against the wall to form a container. Starting at the lowest point, raise the squeegee and pour to form a coating on the walls as the ATLASTIC 50 cools. Continue pouring, overlapping slightly each time, until a uniform thickness results. The ATLASTIC 50 can be smoothed slightly with the squeegee between pours.
- Pour one gallon of melted ATLASTIC 50 at a time onto horizontal surfaces and spread to uniform thickness using a tempered masonite squeegee or a similar material able to be manipulated with one hand. Inspect surfaces for pinholes and mark defects with chalk. Ensure pinholes are covered properly in subsequent applications.
- Apply sufficient coats to form a 1/8" (3.2 mm.) layer. Multiple layers ensure a pinhole free membrane.
- Place ATLASTIC 40 TEXTILE onto the surface and smooth as much as possible. All edges must overlap at least 2" (5.1 cm.). A masonite squeegee can be used as a straight edge to smooth and embed the ATLASTIC 40 TEXTILE into the ATLASTIC 50.
- After the ATLASTIC 40 TEXTILE is placed, apply ATLASTIC 50 to obtain a final thickness of 1/4" (6.4 mm.). Work out all bubbles as the application proceeds. The finish coat must be free of all bubbles and carefully smoothed to provide a uniform finish.

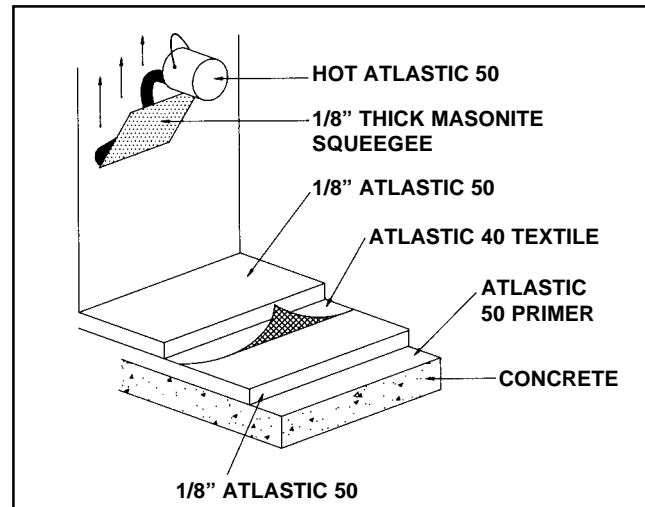
APPLICATION ON VERTICAL SURFACES

- If a 3/8" (9.5 mm.) thick ATLASTIC 50 MEMBRANE is desired, apply as described above, however, place 3/16" (4.8 mm.) thick layers of ATLASTIC 50 instead of 1/8" (3.2 mm.).

Note: Any Atlas Mortar Powder can be sprinkled over the finished surface to prevent sticking to workmen's shoes or boards which have been laid down as walkways. If the powder is used between layers, sweep it up before applying the next layer or the layers will not adhere to each other. **NO TRAFFIC OR EQUIPMENT SHOULD BE ALLOWED ON THE MEMBRANE UNTIL THE BRICK SHEATHING IS INSTALLED.**

Note: It is important that material be held in the melting pot for 4 hours or less. Extensive heating over a prolonged period of time will deteriorate ATLASTIC 50.

CLEANING OF TOOLS AND EQUIPMENT

Kerosene, odorless mineral spirits or hi-flash naphtha may be used for cleaning of tools and equipment. **UNDER NO CIRCUMSTANCES SHOULD KEROSENE BE ADDED TO THE ATLASTIC 50 PRIMER.** Dispose of residues and wastes in accordance with the directions in the Material Safety Data Sheets and government regulations.

STORAGE AND SHELF LIFE

Store all materials in a cool, dry environment. Keep all materials out of direct sunlight. Ideal storage temperature is 75°F (24°C). In unopened original containers, the materials referred to in this Data Sheet have a shelf life of approximately one year.

PRODUCT SPECIFICATION

The membrane shall be ATLASTIC 50 MEMBRANE as manufactured by Atlas Minerals & Chemicals, Inc. The manufacturer shall be ISO 9001 registered for the manufacture and sale of corrosion resistant products.

PRECAUTIONS

The materials referred to in this Data Sheet are for Industrial Use Only. They contain materials that

present handling and potential health hazards. Consult Material Safety Data Sheets and the container labels for complete precautionary information.

TECHNICAL SERVICES

ATLAS maintains a staff of Technical Service Representatives who are available to assist you with the use of ATLAS products. In the event of difficulties with the application of ATLAS materials, the installation should be stopped immediately and ATLAS' Technical Service Department consulted for assistance.

WARRANTY

ATLAS warrants that its products will be free from defects in workmanship and materials under normal use for a period of one (1) year from the date of shipment by ATLAS (provided the products are installed before the expiration of the shelf life). THERE ARE NO EXPRESS OR IMPLIED WARRANTIES OF MERCHANTABILITY OR FITNESS FOR THE PURPOSE FOR THIS PRODUCT WHICH EXTEND BEYOND THE DESCRIPTION ON THE FACE HEREOF. ATLAS' LIABILITY FOR ALLEGED BREACH OF THIS WARRANTY SHALL BE LIMITED TO REPAIR OR REPLACEMENT OF THE DEFECTIVE PRODUCT (BUT NOT INCLUDING REMOVAL OF THE DEFECTIVE PRODUCT OR INSTALLATION OF REPLACEMENT PRODUCTS). ATLAS SHALL NOT BE LIABLE FOR ANY INCIDENTAL OR CONSEQUENTIAL DAMAGES DURING THE WARRANTY PERIOD OR THEREAFTER. **ATLAS' WARRANTY IS VOIDED IF PAYMENT FOR PRODUCT IS NOT RECEIVED IN FULL.**

CHEMICAL RESISTANCE OF ATLASTIC 50 MEMBRANE (4-50PI)

	80°F	150°F		80°F	150°F		80°F	150°F
Acetaldehyde	C	C	Formaldehyde	C	C	Potassium Ferricyanide, Ferrocyanide	R	R
Acetic Acid, to 10%	C	N	Formic Acid	C	N	Potassium Hydroxide, to 30%	R	C
Acetic Acid, Glacial	N	N	Gasoline	N	N	Potassium Hydroxide, above 30%	C	N
Alum or Aluminum Sulfate	R	R	Glycerine	R	R	Pyridine	N	N
Aluminum Chloride, Nitrate, Sulfate	R	R	Gold Cyanide	R	R	Rochelle Salt	R	R
Ammonium Chloride, Nitrate, Sulfate	R	R	Hexane	N	N	Salicylic Acid	R	R
Ammonium Hydroxide	R	C	Hydrobromic Acid	R	R	Silver Nitrate	R	R
Amyl Acetate	N	N	Hydrochloric Acid	R	R	Sodium Acetate	R	R
Amyl Alcohol	R	R	Hydrocyanic Acid	R	R	Sodium Bicarbonate, Carbonate	R	R
Aniline	N	N	Hydrofluoric Acid	C	C	Sodium Chloride, Nitrate, Sulfate	R	R
Aqua Regia	N	N	Hydrofluosilicic Acid	C	C	Sodium Cyanide	R	R
Barium Chloride, Nitrate, Sulfate	R	R	Hydrogen Peroxide	C	C	Sodium Hydroxide, to 30%	R	C
Barium Hydroxide	R	R	Hydrogen Sulfide Gas, Dry or Wet	R	R	Sodium Hydroxide, above 30%	C	N
Barium Sulfide	C	N	Iron Chloride	R	C	Sodium Hypochlorite, to 3%	C	C
Benzene	N	N	Iron Nitrate, Sulfate	R	R	Sodium Hypochlorite, above 15%	N	N
Benzene Sulfonic Acid, 10%	R	R	Isopropyl Ether	N	N	Sodium Sulfide	C	C
Benzoic Acid	R	R	Kerosene	N	-	Sodium Sulfite, Thiosulfate	R	R
Boric Acid	R	R	Lactic Acid	R	R	Soya Oil	N	N
Bromine Water	N	N	Lead Acetate, Nitrate	R	R	Stearic Acid	C	N
Butyl Acetate	N	N	Linseed Oil	N	N	Sulfur Dioxide Gas, Dry or Wet	R	R
Butyl Alcohol	R	R	Magnesium Chloride, Nitrate, Sulfate	R	R	Sulfur Trioxide Gas, Dry or Wet	R	R
Butyric Acid	N	N	Magnesium Hydroxide	R	R	Sulfuric Acid, to 50%	R	R
Cadmium Chloride, Nitrate, Sulfate	R	R	Maleic Acid	R	C	Sulfuric Acid, above 50%	N	N
Calcium Bisulfite, Chloride, Nitrate	R	R	Mercuric Acetate	R	R	Sulfurous Acid	R	R
Calcium Hydroxide	R	C	Methyl Acetate	N	N	Tannic Acid	R	R
Carbon Disulfide	N	N	Methyl Alcohol	R	R	Tartaric Acid	R	R
Carbon Tetrachloride	N	N	Methyl Ethyl Ketone	N	N	Tin Chloride, Sulfate	R	R
Chlorine Dioxide, Water Solution	N	N	Methyl Sulfate	N	N	Toluene	N	N
Chlorine, Dry	R	R	Mineral Oil	N	N	Trichloroethylene	N	N
Chlorine, Wet	R	C	Mineral Spirits	N	N	Trisodium Phosphate	R	C*
Chlorine Water	C	-	Muriatic Acid	R	R	Tung Oil	N	N
Chloroacetic Acid, to 10%	N	N	Nickel Chloride, Nitrate, Sulfate	R	R	Urea	R	R
Chlorobenzene	N	N	Nitric Acid, to 5%	R	R	Xylene	N	N
Chloroform	N	N	Nitric Acid, 5% to 20%	R	C	Zinc Chloride, Nitrate, Sulfate	R	R
Chromic Acid, to 10%	R	C	Nitric Acid, above 20%	N	N			
Chromic Acid, 10% to 50%	C	C	Nitrobenzene	N	N			
Chromic Acid, above 50%	N	N	Oleic Acid	C	N			
Citric Acid, to 10%	R	R	Oxalic Acid	R	R			
Copper Chloride, Nitrate, Sulfate	R	R	Perchloric Acid	N	N			
Dichloroacetic Acid, 10%	N	N	Phenol, to 5%	N	N			
Dichlorobenzene	N	N	Phosphoric Acid	R	R			
Diethyl Ether	N	N	Phosphorous Acid	R	R			
Ethyl Acetate	N	N	Phosphorous Trichloride	R	R			
Ethyl Alcohol	R	R	Phthalic Acid	R	R			
Ethyl Sulfate	N	N	Picric Acid	N	N			
Ethylene Dichloride	N	N	Potassium Bicarbonate, Carbonate	R	R			
Ethylene Glycol	R	R	Potassium Chloride, Nitrate, Sulfate	R	R			
Fluosilicic Acid	C	C	Potassium Cyanide	R	R			

KEY (2-02)

- R - Recommended
- N - Not Recommended
- C - Conditional; May be serviceable if the contaminant is immediately removed or washed off the surface.
- * - For flooring application only.

Note - The information presented in the chemical resistance tables is based on judgments derived from laboratory testing and field service performance. The tables have been prepared as a guide to performance. No guarantee of results is made or implied and no liability in connection with this information is assumed. The information presented herein should be supplemented by in-service testing. The data furnished in the tables may be revised on the basis of further testing.